



Sustainable church heating: The Basilica di Collemaggio case-study



Niccolò Aste, Stefano Della Torre, Rajendra S. Adhikari, Michela Buzzetti, Claudio Del Pero*, Fabrizio Leonforte, Massimiliano Manfren

Department of Architecture, Built Environment and Construction Engineering, Politecnico di Milano, Italy

ARTICLE INFO

Article history:

Received 25 September 2015
Received in revised form 2 December 2015
Accepted 7 January 2016
Available online 8 January 2016

Keywords:

Friendly heating
Local comfort
Pew-based heating
Church heating
Ground-source heat pumps

ABSTRACT

Historic building heating and, in particular, church heating represents a challenging task because many objectives have to be reached simultaneously; in fact, adequate thermal comfort levels have to be guaranteed for the occupants while ensuring an optimal internal climate suitable for the preservation of valuable and often fragile building components and artworks. Moreover, current requirements for sustainability impose to make efforts, where possible, to minimize the amount of energy needed and the consequent environmental impact. For such reasons, the present work addresses in detail the church heating topic, by analysing different feasible strategies and developing subsequently an original technology, able to combine energy efficiency and cultural heritage preservation aspects. The application field of the study is represented by the Basilica di Collemaggio (L'Aquila, Italy), a church of worldwide relevance, currently under restoration. In detail, traditional heating strategies were compared with solutions for the local-comfort, such as the pew-based heating, and a novel hydronic high-efficiency pew-based system was proposed and deeply analyzed. The work demonstrated that such solution is able to combine the advantages obtainable from electric benches with those of a hydronic heating system coupled with ground-source heat pumps, combining good local comfort levels to significant energy savings and low or no impact on the artworks and building structures. The system design was based on a local-comfort assessment, supported by experimental and CFD analyses.

© 2016 Elsevier B.V. All rights reserved.

1. Introduction

In the last 20 years, the debate on sustainability has been implemented also about conservation and management of historic buildings, according to different perspectives. In particular, from the point of view of energy consumption the problem has sometimes been reduced to the enhancement of insulation performances, or to the problem of inserting technical systems in sensitive artistic contexts. The impact of EU directives on energy saving provoked many discussions [1,2], but a research line arose looking for optimal solutions, taking into account also management issues and the effects of climate change [3,4]. The complexity of built cultural heritage allows to deal with all the four pillars of sustainability, that is environmental, economic, social and cultural sustainability [5–8]. Innovative technologies, which entail scientific researches, applied in contexts of outstanding artistic value,

can trigger positive cultural and social processes [9], besides saving energy and money.

Within such context, among historic buildings, ancient churches are those that most frequently have reached the present day practically unaltered. In this way the preservation of their considerable artistic and architectural features was allowed, with particular reference to the artworks contained in them (paintings, frescoes, sculptures, wooden panels, sacred objects, furnishings, organs, etc.). However, even though the mode of use remained almost unchanged over the centuries, in the meantime the comfort needs of modern society have changed, and thus of the churchgoers. In recent years, there is an increasing heating demand for churches, which implies a number of critical issues, as most historic churches were not designed to be heated [10] and it has been underlined how an improper use of heating can even have adverse effects on this particular kind of buildings, their state of preservation and their occupants, such as, for example, thermal stratification, condensation, draughts, heat and humidity imbalances, soiling, fabric and, in general, artefacts stress and deterioration [10–12]. Moreover, objects constituting the interior artistic heritage of a church are generally quite sensitive to environmental factors such as air and surface temperature, relative humidity, light, physical agents,

* Corresponding author.

E-mail addresses: claudio.delpero@polimi.it, claudio.delpero@gmail.com (C. Del Pero).

whose balance is crucial in order to guarantee maintenance and protection of artworks and materials [13–15]. In more detail, periodic air temperature and relative humidity changes may cause dry and wet cycles and air movements that are usually responsible for deterioration and soiling procedures [10,16,17].

Heating can cause a more or less pronounced deviation from the “historical climate” of the church (defined as its unaffected natural condition) to which artworks have become acclimatized, with the result of causing even serious damage to the various artefacts, depending on their vulnerability [18,19]. As a consequence, thermal comfort achievement and artworks preservation often conflict with each other, and a balance between the two needs must be found in order to ensure the public use of the churches without compromising their historical values [17].

In the present paper different technical options are analyzed in order to ensure the most efficient and sustainable church heating solution, with particular reference to a relevant case study, represented by the Basilica di S. Maria di Collemaggio.

In this sense, as it will be shown, the pew-heating concept has been further improved with the matching to hydronic systems and developed for the application purpose.

2. Church heating

Until recently, heating methods for churches were mainly designed to fulfil only economy and thermal comfort requirements, with scarce consideration for conservation issues [18], whereas three factors should be properly considered: occupants' satisfaction, conservation of historic fabric and artefacts [10].

On the contrary, another option is represented by the so-called conservation heating, which can be used to control relative humidity continuously during the year in order to better preserve historic interiors, but is generally characterized by poor comfort performance and high energy demand, and it can hardly be obtained in the huge volumes of many church buildings [20].

In light of the above considerations, it becomes extremely important to identify the most appropriate solutions while designing the heating system of a church, provided that this should have the least possible impact on the local indoor micro-climate [10].

In general two main options have to be considered: central heating (heating the whole room) and local heating (warming people with localized heating sources) [18]. Furthermore, the first option can be divided into continuous and intermittent central heating.

First of all, it has to be noticed that a perfect choice does not exist, as each system has its pros and cons, as well explained in previous research works [13,17,18,21–24].

Although some research studies claim that heating the whole church's volume seems to be an effective way of achieving comfort conditions [10], it can be stated that central heating represents the most problematic and expensive option. This conclusion arises from the observation that the related components (air ducts, radiant floors, radiators) are highly invasive with respect to the existing historical structures and the operation modes have serious impacts on the indoor climate, causing the unwanted fluctuations in temperature and humidity mentioned above. It should also be considered that churches are generally characterized by very high room volumes, whose heating requires significant energy consumption, even in intermittent mode. Nevertheless, a good solution in this sense could be represented by radiant floors heating system, which have been proven to meet thermal comfort and artistic heritage preservation needs, allowing at the same time high energy savings [13]. However it should be noted that this option is feasible only in case of significant restoration work which also affect the church's floors, and that is hardly compatible with the existing artefacts, since often the floors themselves are artworks.

A more effective and less invasive method is to provide localized comfort, by adopting heating systems able to provide direct confined heat just to people sitting, without dispersing too much heat inside the whole church and reducing temperature and relative humidity fluctuations (and thus the related damaging effects) in the proximity of artworks [17]. This strategy could mainly be based on the use of radiant heater placed on the pews, of IR lamps, or else of warm air emission from the floor or footboard [13,17,21,23,25]. These systems have the advantage of providing heat only where necessary and not significantly impact on the overall microclimate of the church, although they are not completely free from drawbacks. IR lamps, for example, can cause glare and also irradiate nearby artworks, damaging them, while heating pews or footboards can cause asymmetric comfort, as commonly only feet and legs are heated [17]. An effective solution has been carried out under the European project Friendly Heating [17,18,26], using electrically heated foils strategically placed on kneelers, seats and backrests of the pews to properly heat the various part of the body. Among the various solutions analyzed, this appears to be definitely the best, both in terms of comfort and artworks conservation, although the heat dispersed by Joule effect adversely affects the overall energy efficiency. Given the quite low operating temperatures, instead of electrical radiant systems, it would be preferable to use hydronic systems, powered by high-efficiency generation systems, such as heat pumps. Of course, the passage of hydraulic pipes is more difficult and invasive compared to wires and can be made only when allowed by the boundary conditions (e.g. interventions on the floor are possible without damaging it).

3. The Collemaggio case study

The Basilica di S. Maria di Collemaggio, L'Aquila, is a masterpiece of Abruzzese Romanesque and Gothic architecture and a very important religious site for the original Papal Jubilee devised by Pope Celestine V, who is buried there. The church is famous for its pink and white stone façade; the interior includes a nave and two side aisles, each one divided from it by a row of columns [27]. The austere character of the interior is due mainly to restoration works completed in 1972, which aimed at restoring the mediaeval appearance that had been changed by the baroque reconstruction after the 1703 earthquake.

The earthquake that struck L'Aquila on April 6th 2009 caused severe damages [28]. The restoration project has been developed using advanced survey, modelling and design techniques, including laser scanning and HBIM [29]. The works had to face many problems, one of them being the problem of heating, which is relevant also because of the local climate: L'Aquila is located at an elevation of m 720 among the mountains and is characterized by severe winters [30].

Given the austere character of the interior surfaces, the problem of their preventive conservation has been deemed less urgent than the requirement of comfort for people. That's why the target of ensuring an artwork-friendly heating has not been dealt with before the opportunity offered by the restoration works. Instead, the presented research has been oriented to design a heating system compatible with both the comfort needs and the preservation requirements. The mediaeval image maintained through restorations is very important in the local community sentiments, and special attention has been paid to the floor of the nave, which is made by the same red and white stone as the façade and absolutely had to remain visible by visitors and churchgoers. For these reasons, the main challenge was to design a heating system comprehensive of its connections and pipes without interfering in the original appearance of the church, able at the same time to preserve the cultural heritage of the Basilica.

Table 1
Main climatic parameters [33].

Site	Latitude	Longitude	Elevation [m]	Heating degree – days	Annual external mean air temp. [°C]	Max. temp. [°C]	Winter design temp. [°C]	Annual global irradiation on horizontal plane [kWh/m ² year]
L'Aquila	42°21'	13°23'	714	2514	11.75	29.1	–5 °C [34]	1436 [35]

According to the described context, in the present work the different feasible heating strategies for the Basilica di Collemaggio are carefully analyzed in Section 4, carrying out energy performance evaluations. Subsequently, the sizing and design of the novel hydronic high-efficiency pew-based system was described in Section 5 and the related performance analysis is explained in Section 6. Lastly, in Section 7 main obtained results are presented.

4. Heating strategies analysis

In this section the main feasible heating strategies analyzed for the Basilica di Collemaggio are described and compared. In detail, as a first analysis, the theoretical thermal energy demand of the building has been calculated through dynamic energy simulation, assuming a constant internal set point temperature during the heating season. By means of the same energy model, the free-floating behaviour of the church was then simulated and assessed, in order to precisely understand the boundary conditions in which the design had to be developed.

Secondly, each considered heating strategy was technically defined and the related thermal and primary energy demand was calculated, based on specific operating profiles; in detail, primary energy was chosen to compare solutions using different energy sources (e.g. natural gas, electricity) because it represents the energy embodied in natural resources that has not undergone any anthropogenic conversion or transformation [31]. According to this principle, natural gas is considered primary energy (primary energy factor equal to 1) while electricity, which is the product of a transformation process, has to be multiplied for the electricity to primary energy factor that is usually greater than 1 to take in consideration the generation efficiency. Such factor is in fact related to the way the electrical energy is produced in a certain context and for Italy is equal to 2.18 [32], therefore this value was assumed in the following calculations.

The sizing of each proposed solution was carried out according to boundary conditions described in Section 4.1. It must be noted that only those heating strategies were analyzed which are actually practicable in the specific context; as an example, under-floor heating and heated footboards were considered unviable in the church's aisles because of aesthetic and conservation requirements of the historic flooring.

4.1. Theoretical thermal energy demand calculation and free-floating behaviour

This section summarizes the data and assumptions used to perform the energy analysis of the Basilica. In particular, an assessment on the climatic context was carried out; the main climatic data are listed in Table 1.

Subsequently, an analysis of the geometrical and thermo-physical characteristics of the Basilica was carried out. The rectangular floorplan of the Basilica (26 m × 95 m) is divided into three areas (a middle nave and two side aisles) separated by arches resting on columns. The middle aisle is 21 m high and the side aisles and high altar (apse and presbytery) 15 m at their highest. Given those dimension, the floor surface of the church is about 2120 m² and its net volume is about 34,800 m³.

The outdoor walls of the church are made of limestone and have a variable thickness from 1 to 2.6 m. The walls of the apses on the indoor side are plastered and whitewashed. The windows in the outdoor walls are made of single glass. The floor in the church is covered with stone tiles. The roof is made of construction wood, covered with roofing tiles. The thickness, thermal transmittance and surface dimensions of the building components are shown in Table 2. The total thermal dispersing surface is 8380 m² and the S/V value is 0.24.

The energy and power demand as well as the free-floating behaviour of the Basilica have been simulated using EnergyPlus software, which represents a widespread and accepted tool in the building energy analysis community around the world. This programme models heating, cooling, lighting, ventilating, and other energy flows as well as moisture in buildings [36]. EnergyPlus does subhourly calculations and integrates the load and system dynamic performance into the whole building energy balance calculations which can provide more accurate simulation results [37,38]. Moreover, this software is particularly suited to simulate dynamic behaviour, strongly influenced by thermal inertia, of historic buildings and was already adopted in the past for similar projects by present authors [39].

In Fig. 1 the simulation model of the Basilica is shown. The climatic hourly data used for simulation is corresponding to a typical meteorological year (TMY) for the reference location (L'Aquila).

The assumptions considered in the analysis are listed below:

- Church's usage profile: 1 celebration per day from Monday to Saturday and 2 celebrations per day on Sunday. Opening hours from 9 to 19 every day. Each celebration lasts one hour.
- Heating set-point air temperature at 1 m above floor-level (in case of all-air systems): 15 °C [40], corresponding to an average air temperature inside the church equal to 20 °C and a maximum temperature at roof level equal to 25 °C [17,22].
- Heating period: from 15 October to 15 April (180 days).
- The internal electric loads were assumed negligible, while the people occupancy was assumed equal to 500 persons during celebrations and negligible during the remaining time, with a specific load of 108 W/person [41].
- Air change rate: considering the few openings in the building envelope and the huge air volume, an average value equal to 0.1 V/h due to natural ventilation was supposed [42,43], during the opening periods. During celebrations, in presence of an all-air system, an air change rate of 0.5 V/h was assumed considering both literature values and the indication from Italian UNI 10339 standard [44].

Table 2
Characteristics of the building envelope.

Structure	Thickness [m]	Thermal transmittance, U [W/m ² K]	Surface [m ²]
Wall	1.0–2.6	0.63–0.26	3685
Windows	0.003	5.8	74
Floor	0.22	3.6	2205
Roof	0.20	0.93	2417

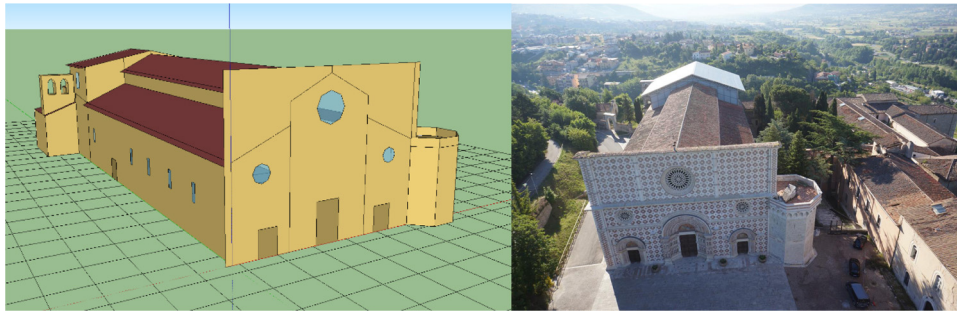

Fig. 1. The simulation model of the Basilica di Collemaggio.

According to the energy simulations, the theoretical thermal energy demand considering continuous heating is equal to 562 MWh/year. The maximum needed thermal power in design day conditions has been evaluated equal to approximately 500 kW.

In free-floating conditions the church's indoor air temperature during the heating season (October–April) has been evaluated comprised between 7.4 and 12.4 °C, with an average value of 9.9 °C; analogously, the temperatures of internal surfaces have been calculated and are characterized by values similar to those of the internal air. Unfortunately, indoor temperature measurements have not been done in the past, before the earthquake, thus no experimental data are available; a monitoring campaign is planned within the restoration works.

Different feasible heating strategies are described hereafter; for each scenario the thermal energy demand and the primary energy demand calculation was performed considering specific technical systems features, daytime operation and assumptions, as described in each section.

4.2. All-air system

In this section the general features of all-air systems for church heating are described and two different solutions are analyzed in detail for the case-study application.

Hot and warm air systems have been commonly used for churches' heating [22,45,46], since they are able to rapidly increase the internal air temperature. They are constituted by a hot-air generator fuelled by natural gas, LPG or diesel, typically placed outside the church and connected to the internal environment with 2 or more air ducts to recirculate and heat the internal air volume. Unfortunately, because hot air tends to flow upwards, in traditional hot air systems a large amount of hot air is forced to circulate in the environment by means of blowers. This hot air flows quickly towards the ceiling, heating that part first, and only later bringing heat at human height, creating a significant thermal gradient along the height of the church [47] and considerably changing relative humidity level. At the same time cold air currents are formed, and they can create discomfort among the occupants. It must also be noted that with such heating systems the indoor air temperature and relative humidity change rates can be higher than the limit suggested in literature to preserve the interior of churches, equal respectively to 2 K/h and 2%/h [48]. In addition, fan operation and air flows typically produce noise inside the heated environment; ducting and grilles are furthermore invasive for historic building. For the analyzed case study, two different all-air systems were analyzed: the first one to be switched on continuously during the church's opening hours, and the second one to be used only when celebrations are held. The specific descriptions and energy calculation are reported hereafter.

4.2.1. All-air system with daytime operation

An all-air system with daytime operation was assumed for the case study, sizing the plant according to the specific features of the building and considering the assumed working profile.

It was assumed that the system is realized by a hot air generator fuelled with natural gas, having a flow rate equal to 35,000 m³/h (of which 15,000 m³/h of fresh air during celebration and 90% recirculation during remaining hours), a nominal power of 500 kW and an outlet air temperature from 35 to 40 °C. The flow rate and the power are designed considering that every morning the heating plant has to increase the internal air temperature from the free-floating value to the set-point value, compensating the heat losses through the envelope and the thermal energy accumulated by the massive structure of the building. The system is thus turned on 1 h before church's opening time at maximum power and flow rate, is adapting the power and the flow rate to the thermal load during the daytime, and is switched off at closing time, with a total daily operating period of 11 h. The system's installation in the Basilica di Collemaggio would require the realization of at least four large grilles in the external walls of the construction to be connected with air ducts.

The total thermal energy demand with the above described all-air system with daytime operation was determined through EnergyPlus simulation and the primary energy demand, equal to 410 MWh/year, was calculated considering a system overall efficiency equal to 95% and an electric power of the fan of 4.5 kW [49].

4.2.2. All-air system with on-demand operation

A system similar to the one described in Section 4.2.1, but with on-demand operation, was assumed for the case study. In detail, it was assumed that the system is realized by a hot air generator fuelled with natural gas, having a flow rate equal to 55,000 m³/h (of which 15,000 m³/h of fresh air during celebration and 90% recirculation during remaining hours), a nominal power of 700 kW and an outlet air temperature from 35 to 40 °C. The flow rate and the power are designed considering that before every celebration the heating plant has to quickly increase the internal air temperature from the free-floating value to the set-point value, compensating the thermal energy adsorbed by the massive structure of the building. The system is thus turned on half an hour before each celebration at maximum power and flow rate, is adapting the power and the flow rate to the thermal load during the celebration, and is switched off at the end of the event. Also in this case the system's installation in the Basilica di Collemaggio will require the realization of at least four large grilles in the external walls of the construction to be connected with air ducts.

The total thermal energy demand with the all-air system with on-demand operation was calculated through EnergyPlus simulation and the primary energy demand, equal to 145 MWh/year, was

determined considering a system overall efficiency equal to 95% and an electric power of the fan of 7 kW [49].

4.3. Infrared heaters

An alternative solution to all-air systems in large-volume buildings like churches can be radiant heating systems using direct radiant heaters suspended above the occupied zone, thus in this section two different technical solutions based on infrared radiant heaters were assessed for the case-study. In particular, systems using direct radiant heaters reduce the problem that occurs with convection heating, related to the upward movement of warm air because people are heated by means of electromagnetic waves, whereas the air in the room is heated indirectly, as a result of heat emission by elements that have already been heated [48]. The radiant heater systems also have little thermal inertia and should be operated just during church's occupation. The two main types of IR heaters are described below.

4.3.1. Gas-fired infrared heaters

A gas-fired IR system was assumed for the case study, sizing the heaters according to the specific features of the building and considering the supposed working profile. In detail it must be noted that, in the gas-fired emitters, typically used in large buildings, the combustion takes place directly in each heater, thus the exhaust gases are typically discharged in the heated environment causing internal pollution and possible vapour condensation on building surfaces. Different sizing and designing criteria can be derived from literature for such systems [50,51], but in the specific evaluation the sizing proposed within a previous feasibility study for the church's renovation was considered. According to such design, 20 gas-fired infrared heaters with a nominal power of 19 kW each (380 kW in total) were considered, homogeneously distributed along the church and installed at 8 m above the floor level. The system is thus turned on during each celebration at nominal power and is switched off at the end of the event.

The total primary energy demand with gas-fired infrared heaters, equal to 78 MWh/year, was calculated multiplying the total installed power for the working period during the heating season, without considering any electric auxiliaries.

4.3.2. Electric infrared heaters

Similarly to the configuration described in Section 4.3.1, also an electric IR system was assumed for the case study. In this case the source of thermal energy for radiant heaters can be also electricity in case of quartz tube or quartz halogen heaters; the system configuration is very simple and there is no local emission of pollutant or vapour, since each heater is simply connected to the grid; unfortunately for large buildings the required electric power can be huge, requiring a medium voltage connection. In the Basilica di Collemaggio, the same power designed for gas-fired heaters was assumed to carry out energy evaluation (i.e. 380 kW_{el}), and the total primary energy demand, equal to 168.5 MWh/year, was calculated multiplying the total installed power for the working period during the heating season and taking into account the primary energy factor.

4.4. Pew-based heating

As previously introduced, pew-based heating is an interesting technical solution for local thermal comfort, thus also such solution was assessed for the analyzed case-study; recent research [17] demonstrated that novel technical solutions integrating electric heating foils properly installed as under-seat, under-kneeler and hand-warmer elements can ensure optimal comfort level while minimizing the negative influence on the church and its artworks.

In general, heating can be generated with heating foils or with resistances, with power ranging usually from 50 to 300 W/m² [52,53] and the system can be switched on just a few minutes before celebrations thanks to its very low thermal inertia and warming up period. Literature data demonstrate that significant savings are achievable with such technical solution, typically higher than 70% in comparison with on-demand all-air systems [54].

However, the sizing of a pew-based heating system requires a detailed assessment on radiant surfaces positioning and related view factors as well as specific local comfort analysis, in order to ensure a proper functioning. In addition, it must be noted that the heat generation with Joule effect could not be considered optimal under an exergy point of view, relying on a strong energy degradation.

In order to overcome this drawback, in the present research an innovative hydronic solution has been presented and assessed in Sections 5 and 6; features and performances of such solution are described below and a final energy comparison with the electric alternative has been carried out considering the same sizing criteria, as described in Section 7.

5. Sizing and design of a high-efficiency hydronic pew-based heating

Considering that pew-based heating requires low surface-temperatures, the solution is fully compatible with hydronic systems coupled with high-efficiency generators such as heat pumps [55]. In the present work, a novel high-efficiency hydronic pew-based heating system is thus proposed and specifically designed for the Basilica di Collemaggio. In such technical configuration the heat transfer fluid (water) is heated at 35–40 °C by the generator, which is a water-to-water heat pump, and is distributed through small pipes to the benches and the heated footboards. The pews thus integrate hydronic radiant panels placed in order to maximize the heating surface and the related view factor in respect to seated peoples. In the specific case-study, a detailed verification of the existing constraints was carried out in order to ensure the feasibility of such solutions. In detail, it was attested that different groups of benches can be hydraulically connected with a heat pump placed in a technical room by means of small-diameter copper pipes which can be placed underfloor by raising and then repositioning few rows of tiles, without altering the state of conservation of the floor. Then, it was proven that vertical boreholes can be realized outdoor at the back of the church, allowing to use a geothermal heat pump with high COPs. A general working scheme of the system is proposed in Fig. 2.

In the following sections the sizing and design of the hydronic pew-based heating system is described, according to the general configuration as mentioned before. It should be noted that the system integration in the benches and the layout of these in the aisle does not prevent the view of the floor from visitors and churchgoers, which was one of the main objectives of the project.

5.1. Local comfort evaluation and system preliminary sizing

Starting from the argumentation described in the introduction, several technical aspects have been considered in the definition of the technical systems for the Basilica di Collemaggio. First of all, the two fundamental topics jointly considered in modelling and design are, respectively, the dynamic hygro-thermal behaviour of the building and the comfort perceived by churchgoers.

The computational models used to assess the local thermal comfort have been developed within previous research related to comfort conditions localized and customized for seated persons

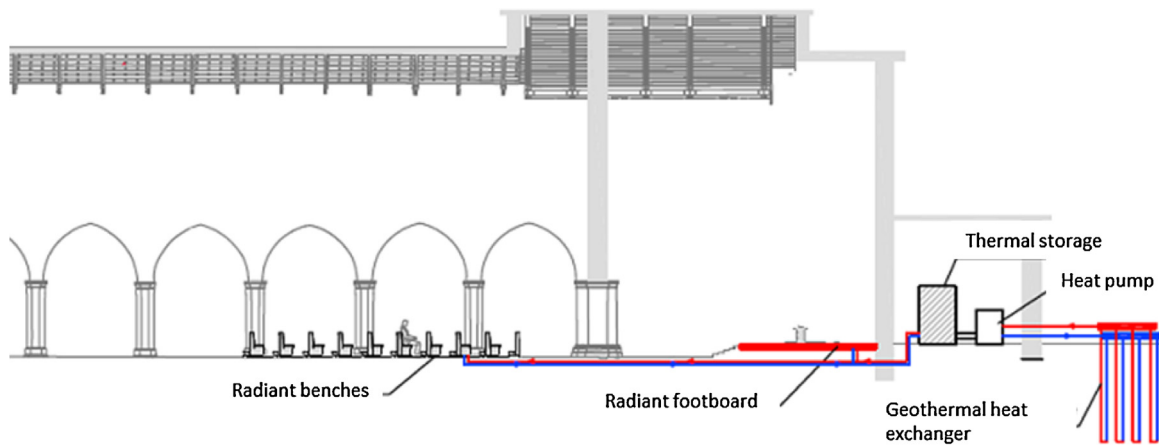

Fig. 2. General scheme of the high-efficiency hydronic pew-based heating.

[56], where specific evaluations have been carried out on the mechanisms of conduction, convection and radiation of the human body.

In detail, the adopted method is based on the subdivision of the human body into segments, which correspond to the individual parts of the model (body model used for simulating fluid dynamics) and the calculation of the equivalent temperature (t_{eq}) for each segment. The equivalent temperature is the temperature of an imaginary enclosure with the mean radiant temperature equal to air temperature, in which a person has the same heat exchange by convection and radiation as in the actual conditions [41].

This subdivision allows to evaluate the sensation of comfort (or discomfort) in detail in the different parts of the body of seated person and also indicates the overall result obtained for the entire body, which is the average weighted temperature in the different points of the body. The representation of the level of comfort is therefore a function of the position (segment of the body) and the equivalent temperature, as shown in Fig. 3 [56].

More specifically, the methodological approach for the design of the local heating system (pew heating) and the verification of its effects in terms of thermal comfort are the following:

1. definition of the geometric characteristics (dimensions) of the pew and of the radiant elements inserted in the pew (positions in the space and dimensions); in detail, a 5-seats wooden bench with dimensions equal to (L × H × W) 276 cm × 80 cm × 70 cm was designed in order to integrate hydronic radiant surfaces placed behind the back of the bench and under the seat according

to the arrangement shown in Fig. 4. As previously noted, the disposition of the radiant surfaces was decided in order to maximize the radiant effect and the possibility for the churchgoers to see the historic floor of the Basilica. The total radiant surface for the 5-seats bench in the proposed configuration is approximately equal to 1.8 m².

2. calculation of view factors of radiant surfaces with respect to the body parts of a person seated in the pew;
3. calculation of surface temperatures of the different elements constituting the pew (seat, back, etc.) using a model of a low mass radiant heating system [57];
4. calculation of the local air temperature increase due to the convective effect of the heating system;
5. calculation of the equivalent temperature on the parts of the body of a seated person;
6. use of the calculated t_{eq} for the verification of the average comfort index (whole body sensation) and the comfort in the different body parts (local sensation);
7. verification of the comfort indexes for various operating conditions, corresponding to different radiant temperatures.

Specifically, the calculations have been carried out for the coldest month of the year (January), which represents the most unfavourable climatic condition.

As regards the local comfort diagrams obtained with the simulations, the supply water temperature to the system was supposed to vary from 30 to 45 °C in order to analyze different reasonable scenarios, taking in consideration the maximum temperature for radiant heating surfaces suggested by the UNI EN 1264 standard, which is varying from 29 °C (floors) to 40 °C (walls).

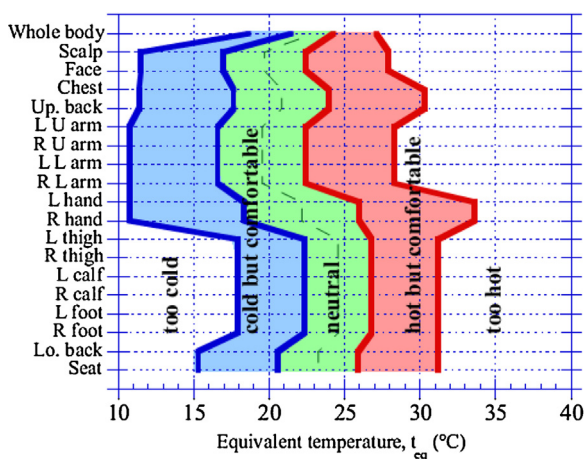

Fig. 3. Example of winter comfort zones for different segments of the body. Abbreviations refer to L = left, R = right, U = upper.

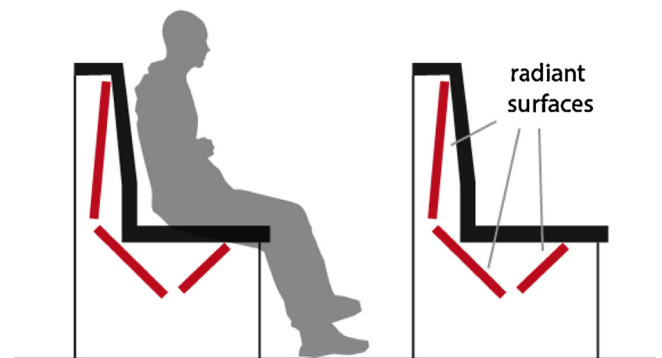

Fig. 4. Schematic of the radiant surfaces of the bench.

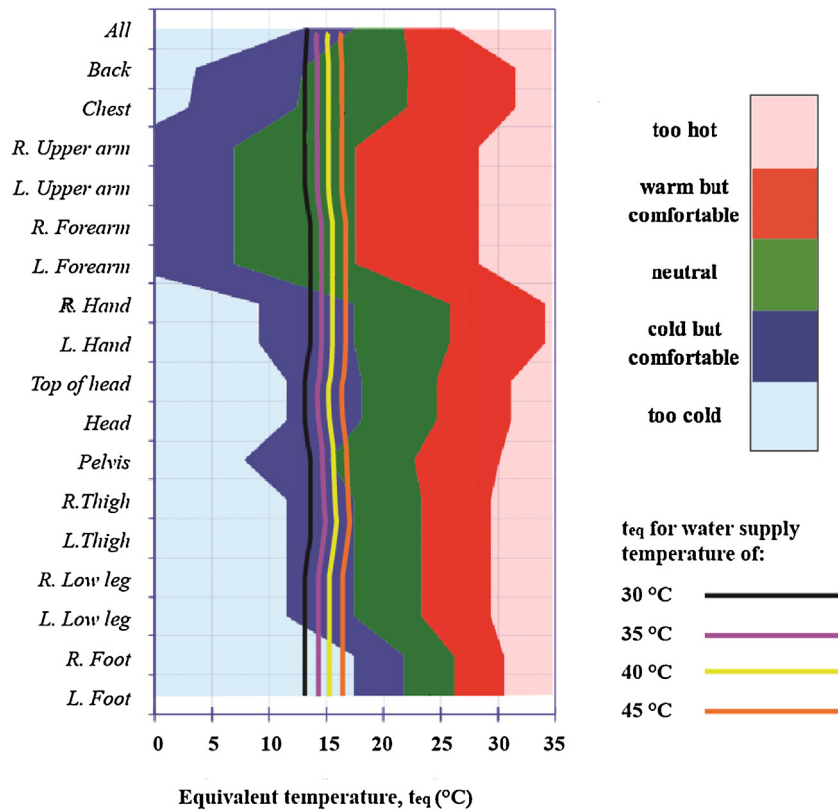

Fig. 5. Local comfort diagramme for supply water temperature equal to 30, 35, 40 and 45 °C.

The value of clothing ($clo = 2.1$) corresponds to typical winter cloths with overcoat (open at front part around the chest, as is likely for a person coming from outside and sitting in church).

The constraint regarding the possibility to leave free as possible the view of the floor, which is a part of the artwork of the Basilica, poses the problem of a reduction in the comfort level around the foot area. This limitation is considered acceptable, however, in relation to the overall perception of comfort by the occupants (average body) and the aesthetic value of the floor, which, otherwise, would be hidden by other types of system solutions.

Fig. 5 shows the results of the calculation of the comfort level. In detail, the body is divided in different segments (L=left, R=right, U=upper) and the different colours indicate the expected comfort level; considering different supply water temperatures, the solid lines trace the equivalent temperature calculated for the analyzed technical solution.

For all the analyzed supply water temperatures, the comfort condition for most of the part of body is just below the level of neutrality, however, still comfortable (except the foot area). In the latter, there is a slight discomfort at lower part of the body and around head.

Considering that the COP (coefficient of performance) of a water-to-water heat pump is decreasing with the increasing of the temperature difference between the heat source and the generated heated water, according to an exponential function related with the Carnot efficiency [58], it is better to minimize the supply water temperature of the system to obtain the maximum energy

performance and also to reduce the thermal losses of the distribution pipes. However, the equivalent temperature profile obtained with supply water at 30 °C was considered too close to the discomfort zone for some parts of the body, therefore the minimum optimal value was conservatively considered equal to 35 °C. The subsequent detailed system design and experimental analysis were carried out assuming such value.

5.2. System final design

Considering the abovedescribed general system configuration and the preliminary design of the radiant bench defined in Section 5.1, the final design of the hydronic pews was carried out as described hereafter. In detail, the radiant plates have been realized with extruded aluminium profiles, specifically adapted for the purpose. These elements are provided with internal ducts with circular section, in which the heat transfer fluid flows, and can directly be covered with a thin layer of wood as a finishing. Each radiating element is equipped with a specific mechanical coupling system that ensures the interconnection of different elements, forming one modular radiant surface with high mechanical resistance, as shown in Fig. 6.

The solution ensures optimal thermal performances, good mechanical strength and easy assembly if compared with other alternatives to obtain similar hydronic radiant surfaces (e.g. radiant panels integrating plastic pipes).

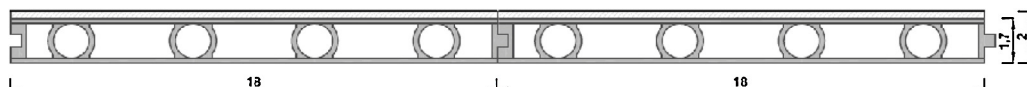

Fig. 6. Hydronic radiant plates realized by extruded aluminium profiles.

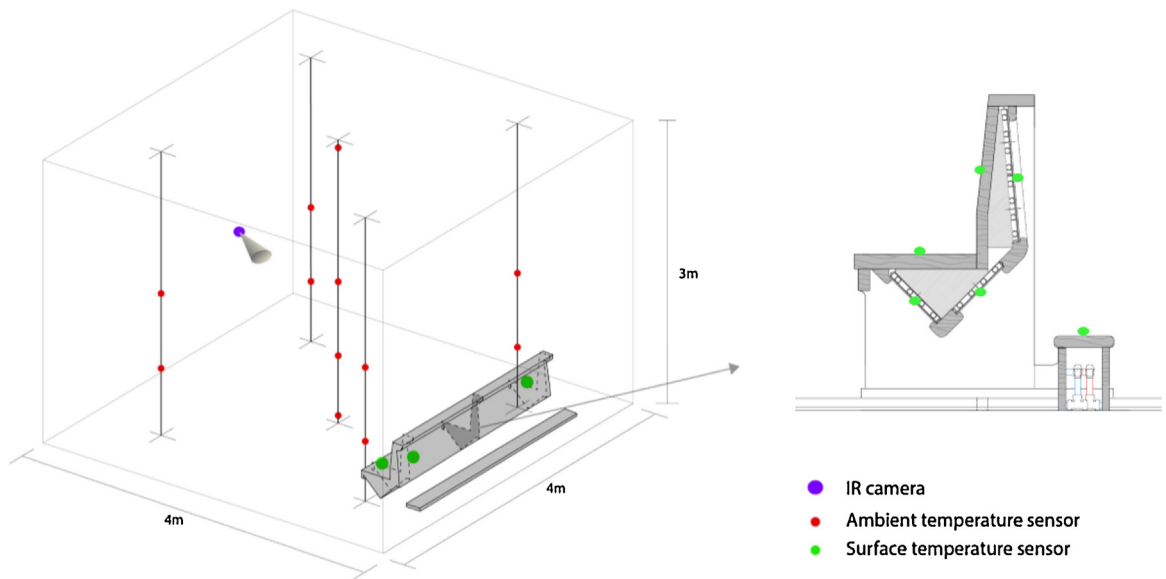

Fig. 7. Camera and sensors layout.

For each bench, 4 hydronic plates having dimensions equal to (L × H × W) 255 cm × 2 cm × 18 cm are used: 2 of them are coupled together and vertically placed behind the back of the bench, while the other 2 are installed under the seat, one tilted forward and the other backward, according to the scheme shown in Fig. 4.

All the plates are hydraulically connected in series and the first plate at the top and the last one at the bottom of the bench are attached with the inlet and outlet copper pipes which connect each pew with the main hydraulic circuit. The wooden structure of the bench is designed to fully integrate all the pipes and the joints, and is provided with different openings in order to ensure an easy access in case of maintenance. The hydraulic interconnection among different pews is realized with above-floor copper pipes hidden in a wooden channel.

The thermal design of the system was carried out considering to obtain a useful radiant surface thermal power of 120 W/m² with an inlet water temperature of 35 °C, an heat drop of 2.5 °C and an air temperature of 20 °C; the resulting flow rate is thus roughly of

75 kg/h. The corresponding maximum power with air temperature equal to 10 °C is calculated to be equal to approximately 220 W/m² with heat drop of roughly 4.5 °C. In order to define the design conditions, an average useful thermal power equal to 220 W/m² (approximately 400 W per bench) was considered as a reference value; the water flow rate will be thus adjusted in order to ensure such power in different boundary conditions. The whole heating system was thus designed assuming a heat pump with a nominal power of 30 kW (brine input temperature of 0 °C and water output temperature at 40 °C) coupled with a geothermal heat exchanger realized with 4 boreholes, 150 m-deep each. The total power of the generator is the one conservatively needed for a total number of 64 benches.

With the aim to carry out energy evaluations, a seasonal coefficient of performance (SCOP) of the geothermal heat pump system equal to 4 was assumed as a reference value [59]. It takes into account also electric consumption due to required auxiliaries. The entire system is supposed to be turned on 1 h before each

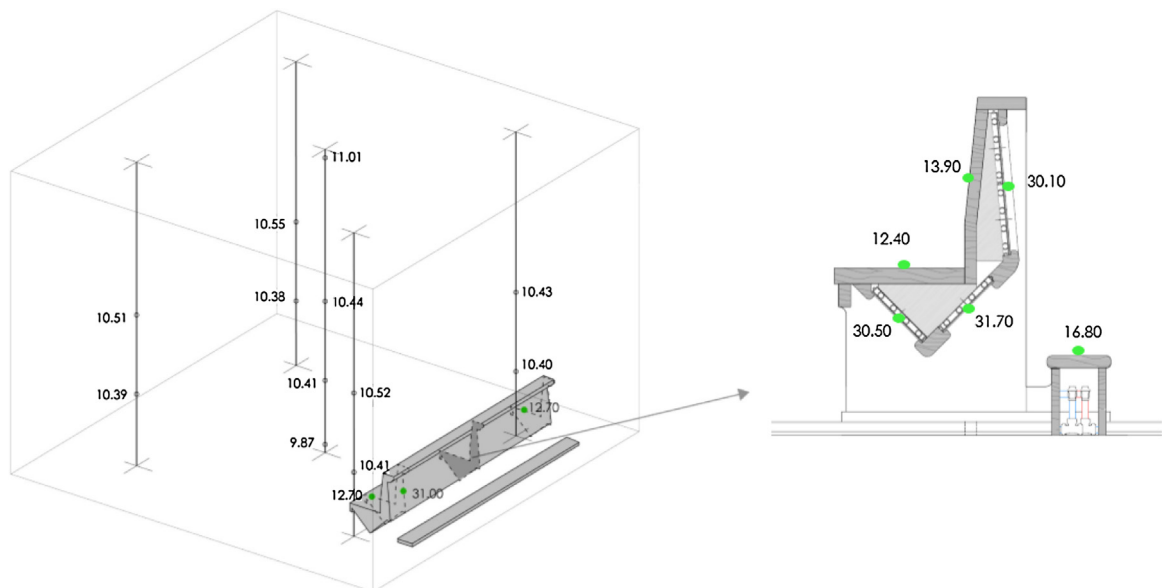

Fig. 8. Measured ambient and surface temperatures [°C].

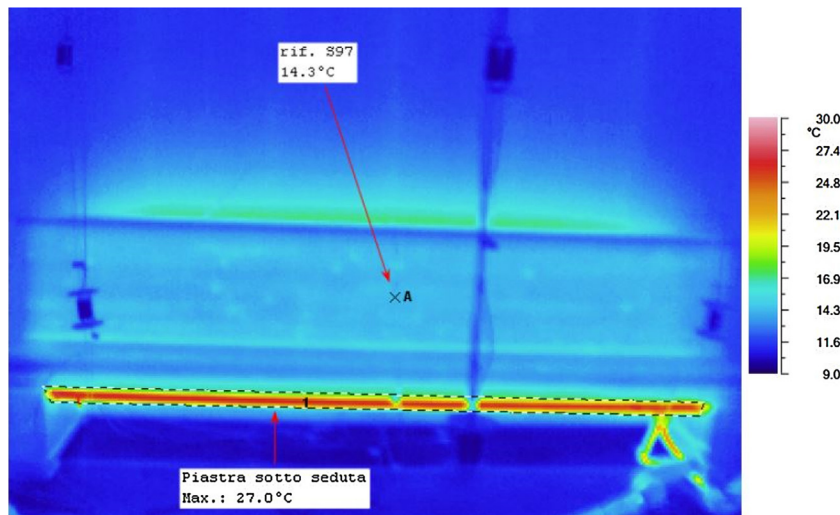

Fig. 9. IR acquisition.

celebration at nominal power and to be switched off at the end of the event.

The total primary energy demand with the hydronic pew-based heating, equal to approximately 6.7 MWh/year, was calculated by dividing the total thermal energy demand, which is the product of the reference thermal power of the plant (30 kW) and the supposed working period during the heating season, for the SCOP value, and taking into account the above-mentioned electricity to primary energy factor of 2.18.

6. Performance analysis

In the following section, the experimental analysis carried out on a prototype bench and the related computer simulation are described. More in detail the performance analysis were performed in three steps. First of all the thermal performance of a real prototype under controlled condition was evaluated at the environment test chamber of M.R.T. laboratory (Laboratorio Misure Ricerche Termotecniche) at Politecnico di Milano. Then, the evaluation was enhanced by means of a virtual model which is calibrated according to experimental results. Finally the calibrated model was applied to a simulation of the benches installed in the church environment. Analytical and experimental results are discussed in the followings paragraph.

6.1. Experimental analysis

In order to verify the effectiveness of the proposed solution, a prototype of the designed heating system was realized by the Politecnico di Milano and tested according to EN 442-1/2:2014 [60,61] standard in a environmental test chamber. The main goal of the experimental analysis is the evaluation of the radiant system performance in term of power and heat delivery, verifying at the same time the compliance with the surface temperatures' constraints reported in the literature [62].

- The environment test chamber was equipped with a real time monitoring system, which consists in:
- sensors able to measure the water temperature at inlet and outlet of the heating system pipes;
- temperature sensor placed in the main bench surfaces (according to Fig. 7);
- ambient temperature sensors (according to Fig. 7);

- IR camera to measure the surface temperature of the bench heating;

The prototype, placed next to a chamber's wall as shown in Fig. 7, was tested by setting an equal value for ambient temperature and surfaces temperature approximately of 10 °C, according to the average free-floating values presented in Section 4.1. The flow rate of the circulation water has been set at 75 kg/h, according to the design value, with a resulting temperature drop between inlet and outlet water flow equal to 5.1 °C (inlet at 36.2 °C and outlet at 31.1 °C).

The experimental results show that, during operating conditions, the heating system provides a power of 451 W equal to 250 W/m², even slightly higher of the designed one.

As shown in Fig. 8, the bench temperatures measured respectively at the seat and the seatback reaches a temperature slightly lower than 15 °C, while the radiant surfaces reach temperatures over 30 °C as also shown by IR measurement carried out on the front side of the bench (Fig. 9).

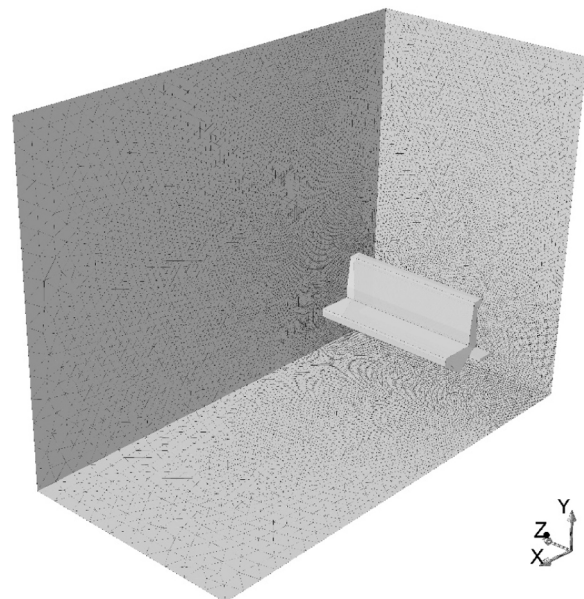

Fig. 10. CFD model.

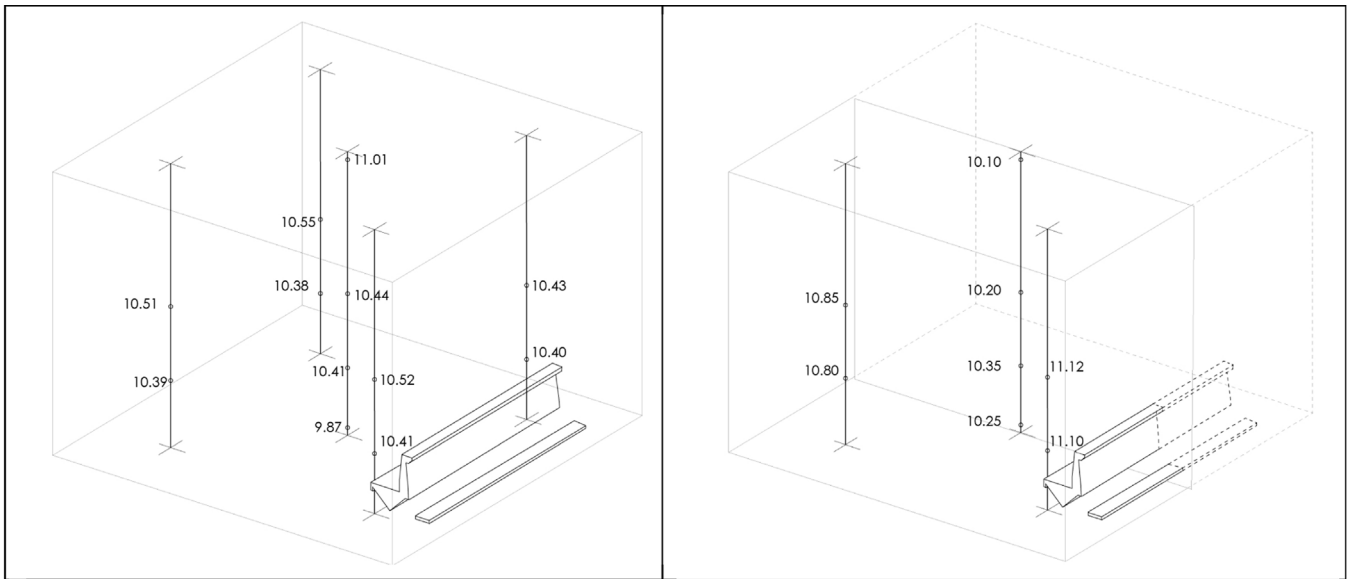

Fig. 11. Air temperatures comparison between experimental (left) and simulated data (right).

It can be observed from Fig. 8 that the maximum air temperature monitored along the environmental test chamber is equal to 11.01 °C, only about 1 °C higher than the set point.

The main advantage of the proposed system, in fact is that the air is not heated towards high temperatures while the heat is radiated to people directly, avoiding furthermore discomfort due to hot surfaces in contact with the human body.

6.2. Computer simulation

In order to assess the actual performance of the bench heating system in the church, the related thermal comfort and hence the air and the mean radiant temperature distribution, a CFD analysis is necessary. As a first step, a simulation of the bench placed in the environmental test chamber was performed. This simulation allowed to calibrate the model according to the measured experimental values. The main results of the analysis are described in the next section. After that, according to the model set-up adopted in the calibrated model, the influence of the local

heating system placed in the church is shown and discussed in Section 6.2.2.

Within this research, the CFD package Fluent (version 15), which is one of the most widespread fluid dynamic software, was applied.

6.2.1. Model validation

The simulation model of the bench placed in the environmental test chamber was realized using Cartesian coordinates, in which an unstructured tetrahedral grid is applied. In order to reduce the computational time, only a half of the model was realized and a symmetric plane was applied as boundary condition. It was considered reasonable because, given the physical geometry under study, the expected pattern of flow and the temperature distribution are symmetrical considering the middle x–y plane shown in Fig. 10.

Within this CFD model, the following equations and the related discretization schemes were considered:

- heat transfer: the convection-diffusion equations is solved with the second Order Upwind discretization method;

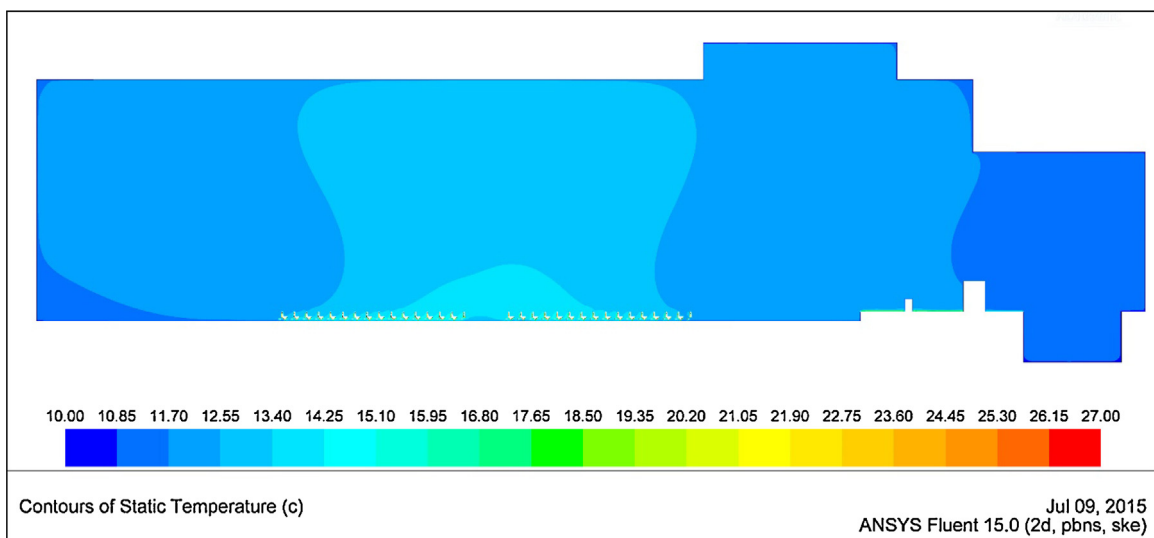

Fig. 12. Air temperature distribution along the church.

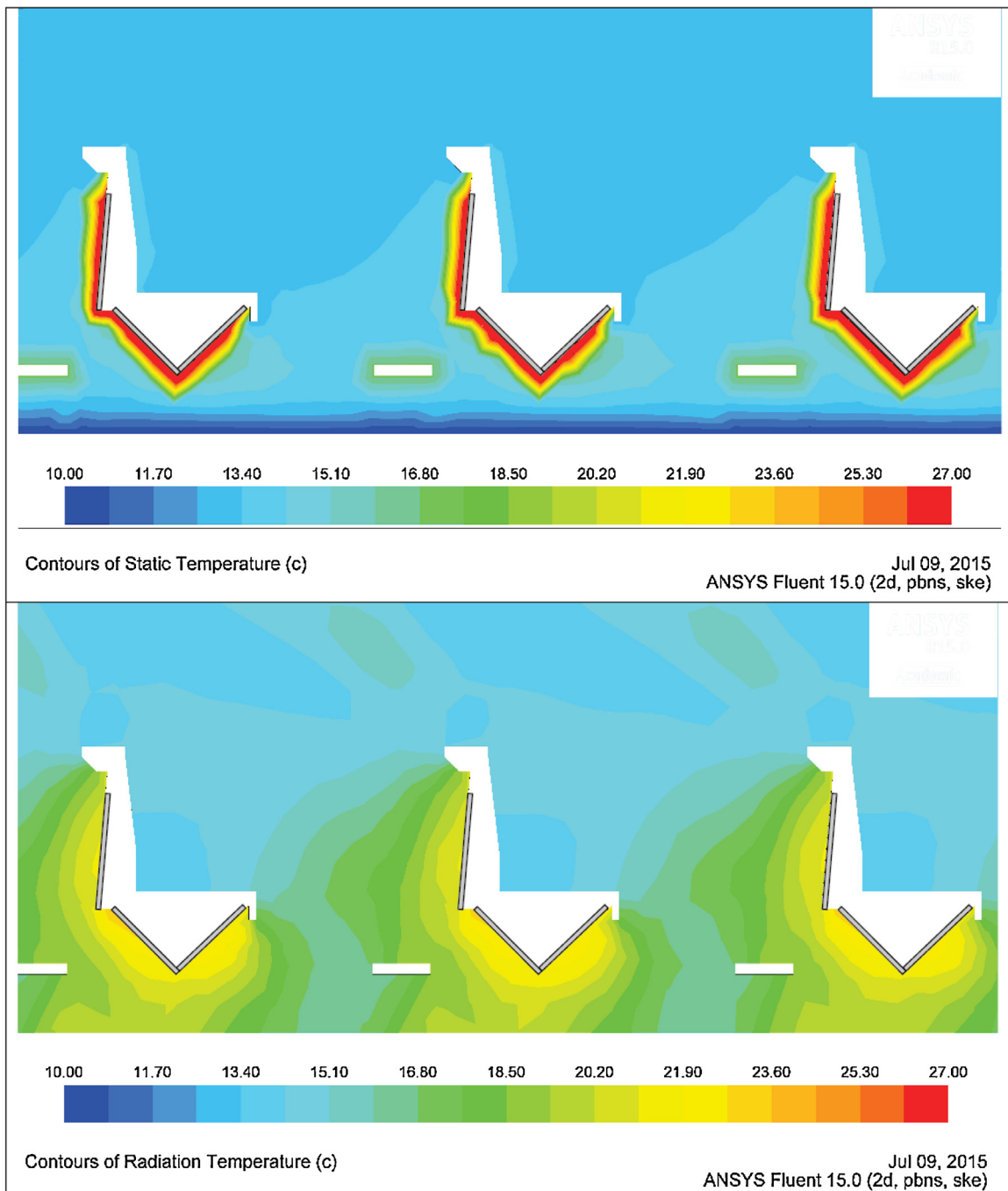

Fig. 13. Comparison between the air temperature and the radiant temperature distribution along the benches.

- radiative exchanges: the radiative exchanges modelled with the Discrete Ordinates were solved with the first Order Upwind;
- viscosity: turbulence was considered in the $k-\varepsilon$ model with standard wall functions and solved with the first Order Upwind;

The pressure-velocity coupling was evaluated according to the SIMPLE algorithm which uses a relationship between velocity and pressure corrections to enforce mass conservation and to obtain the pressure field.

Because no forced ventilation is provided, while heat is supplied by radiation and natural convection from the heating elements, the Boussinesq approximation was used for the air density.

The radiant plates and the wooden structure of the bench were modelled as a whole object, characterized by different surface

temperatures according to the measurements carried out in the environmental test chamber and reported in Fig. 8. This approach is considered reasonable since the scope of the analysis is to validate the CFD model in order to obtain the air temperature distribution on the local environment due to the heating system, on the basis of the measured surface temperatures of the bench. It must also be noted that in the prototype system the heating plates are directly coupled with the wooden structure, which is fabricated with dried laminated wood that has a high resistance to thermal stress. For this reason the temperature distribution inside the wooden layers of the bench was not analyzed in this phase of the research.

An emissivity of 0.94 was set in the simulations; such value was defined through the experimental measurements by comparing

the temperature measured by the IR camera and the temperature measured by surface sensors.

The wall boundary conditions as well as ceiling and floor temperature was set to 10 °C, according to the experimental analysis.

In Fig. 11, the air temperature measured in the experimental analysis (image on the left) is compared to the one calculated with the CFD simulation (image on the right). As already mentioned, since the simulation model was considered symmetrical, the results are related to an half of the room. The comparison shows a good agreement between measured and simulation data, with an error in air temperature from 0.5% to 6%.

It has already been noted that the proposed heating system does not significantly increase the air temperature of the room, since the main benefit is due to radiation effect, as shown in the next section.

6.2.2. Church's CFD analysis

The effectiveness of the proposed heating system was simulated also considering the whole church's environment. The boundary conditions as well as the solver method used were set according to the simulation described in Section 6.2.1. However, due to the huge dimension of the Basilica, the further model was realized in 2 dimensions.

Fig. 12 presents the simulation results, in terms of air temperature distribution in the main section of the church. It shows that the increase in air temperature in the upper part of the church during the heating system operations is about 2.5 °C, and thus it does not cause abrupt or substantial changes in temperature.

As already said, the main advantage of the local heating system is that the air in the church is not heated towards high temperatures, but that the heat is directly radiated to people. Fig. 13 shows the air temperature around the church benches in comparison with the radiant temperature. Whereas the air temperature around the benches only rises slightly (with a temperature of about 13 °C), the radiant temperature at the positions where the people are seated reaches a level of 17 °C or higher. It can be considered an acceptable level for providing human thermal comfort, according to the results of the comfort analysis presented in Section 5.1.

7. Results and discussion

The presented work shows how it is possible to improve the indoor comfort conditions of a sensitive historical building without causing impacts on its conservation state and in an energy efficient way. In this sense the local heating system developed proves to be particularly effective.

The detailed performance assessment carried out through experimental evaluations and CFD analysis described in Section 6 demonstrated that the proposed pew-based heating solution is able to ensure the expected local comfort level in the considered case-study, minimizing the influence on the church internal environment and thus on its artistic heritage. Also under the energy and environmental point of view, the hydronic pew-based system was compared with the other feasible heating strategies analyzed for the Basilica. In detail, the obtainable results for each case, in terms of primary energy consumption during the heating season, are summarized in Fig. 14, on the basis of the calculation methods previously described in Section 4 and the above-introduced primary energy factors (1 for natural gas and 2.18 for electricity).

As stated before, for the electric and hydronic heating solutions the same total thermal power delivered by the system (30 kW) was assumed, while the operating period was set equal to 1.5 h for each celebration for the electric version and to 2 h for the hydronic version, in order to take into account the different warming-up periods.

As it can be noted, all on-demand heating solutions are in general able to strongly reduce the energy consumption compared

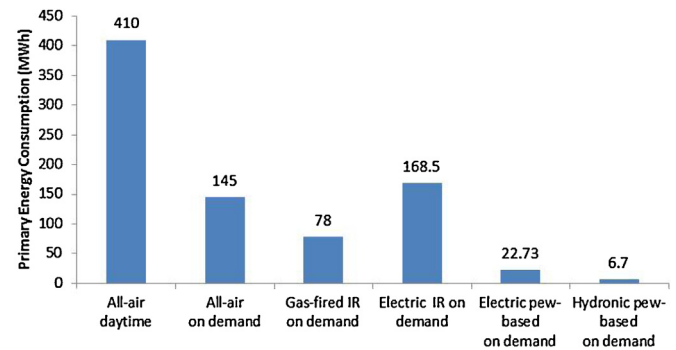

Fig. 14. Comparison of the primary energy consumption of the different feasible heating solutions analyzed for the Basilica di Collemaggio during the heating season.

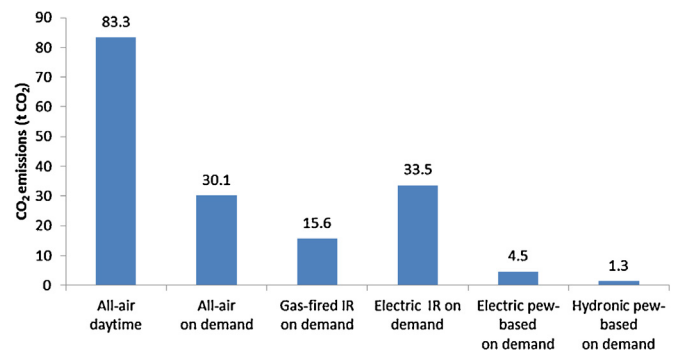

Fig. 15. Comparison of the yearly CO₂ emissions of the different feasible heating solutions analyzed for the Basilica di Collemaggio.

to a standard all-air system with continuous daytime operation. In addition, the resulting primary energy saving related to pew-based systems is substantial if compared with the consumption of all the other analyzed alternatives, even limiting the confrontation to on-demand heating solutions.

It has also to be noted that the proposed hydronic system reaches a further reduction of the consumption by approximately 70% if compared to similar electric heating systems, thus minimizing the primary energy demand, the operational cost and also the environmental impact (due to the energy-related greenhouse gasses emissions). In this respect, a comparison was carried out also considering the specific yearly CO₂ emission of each solution, as reported in Fig. 15. The emission factors were considered 0.2 kg CO₂/kWh for natural gas and 0.433 kg CO₂/kWh for electricity, according to the ones actually adopted in Italy [63,64]. It can be observed that the trend of the CO₂ emissions follows approximately that of the energy consumption.

8. Conclusions

In the present paper different strategies for church heating considering a relevant case-study, the Basilica di Collemaggio (L'Aquila, Italy) are analyzed and compared. The work allows to confirm that pew-based friendly heating is an effective solution for historic churches because it combines good local comfort levels with significant energy savings and low or no impact on the artworks and on the building structures. In particular, a novel hydronic high-efficiency system, which is able to combine the advantages of radiant benches with those of water-to-water ground-source heat pumps, is presented.

In essence, the work demonstrates that such system is highly sustainable [65] since it is able to:

- significantly reduce the thermal energy need while providing good local comfort;
- use high-efficiency energy solutions for thermal energy generation;
- cover a considerable part of the demand using renewable energy;
- reduce the amount of GHG emission related to heating needs.

In future developments the research will be deepened regarding the experimental measurement of the comfort levels which the system is able to ensure, in order to consider possible improvements of the proposed configuration.

Furthermore, once implemented the project (currently under construction), the novel heating system will be tested and verified in detail under actual operating conditions, in the Basilica's environment.

Acknowledgment

The authors would like to thank ENI, which has financially supported the restoration of the Basilica and the M.R.T laboratory (Laboratorio Misure Ricerche Termotecniche) for carrying out the experimental measurements on the bench.

References

- [1] T. Nypan, The inadvertent impact of EU Directives on Cultural Heritage and a possible solution, European Heritage Head Forum, Prague, May 9–11, 2001.
- [2] E. Lucchi, V. Pracchi (Eds.), *Efficienza energetica e patrimonio costruito. La sfida del miglioramento*, Maggioli, Rimini, 2013.
- [3] M. Cassar, Sustainable heritage: challenges and strategies for the twenty-first century, *ATP Bull.* 40 (1) (2009) 3–11.
- [4] S. Staniforth, Slow Conservation, *Stud. Conservat.* 55 (2) (2010) 74–80.
- [5] R. Mioili, K. Van Balen, A. Vandesande, Costing the built environment: towards a policy of strong sustainable development. Quale sostenibilità per il restauro? in: International Conference "Scienza e Beni Culturali" Proceedings, Arcadia Ricerche, Venezia, 2014, pp. 457–467.
- [6] G. Franco, S.F. Musso, A "comprehensive sustainability". New design paradigms and methods for maintaining, conserving and managing monuments and traditional architecture. Quale sostenibilità per il restauro? in: International Conference "Scienza e Beni Culturali" Proceedings, Arcadia Ricerche, Venezia, 2014, pp. 53–63.
- [7] Cultural Heritage counts for Europe. Final report. www.encatc.org.
- [8] B.M. Feilden, *Conservation of Historic Buildings*, Butterworth Architecture, Oxford, Boston, 1994.
- [9] S. Della Torre, Planned conservation and local development processes: the key role of intellectual capital, in: K. Van Balen, A. Vandesande (Eds.), *Reflections on Preventive Conservation, Maintenance and Monitoring*, Acco, Leuven, 2013, pp. 123–127.
- [10] M. Makrodimitri, S. Papavasileiou, J.W.P. Campbell, K. Steemers, Heating historic structures. A review of heating systems in historic church buildings and implications related to conservation and comfort. The case of four historic churches in Cambridge, in: *Proceedings of Energy Management in Cultural Heritage Conference*, 2011.
- [11] W. Bordass, C. Bemrose, *Heating Your Church*, Church House Publishing Ltd, London, 1996.
- [12] D. Camuffo, *Microclimate for Cultural Heritage: Conservation, Restoration, and Maintenance of Indoor and Outdoor Monuments*, Elsevier, 2013.
- [13] T. Cardinale, G. Rospì, N. Cardinale, The influence of indoor microclimate on thermal comfort and conservation of artworks: the case study of the Cathedral of Matera (South Italy) *Energy Proc.* 59 (2014) 425–432.
- [14] D. Camuffo, G. Sturaro, A. Valentini, M. Camuffo, The conservation of artworks and hot air heating systems in Churches: are they compatible? The case of Rocca Pietore, Italian Alps, *Stud. Conservat.* 44 (1999) 209–216.
- [15] H.L. Schellen, Heating monumental churches: indoor climate and preservation of cultural heritage (Doctoral Thesis), Technische Universiteit Eindhoven, 2002.
- [16] T.M. Olstad, A. Haugen, T.N. Nilsen, *Polychrome wooden ecclesiastical art – climate and dimensional changes*, NIKU Publications, Oslo, 2001, pp. 1–24.
- [17] C. Dario, E. Pagan, S. Rissanen, Ł. Bratasz, R. Kozłowski, M. Camuffo, A. della Valle, An advanced church heating system favourable to artworks: a contribution to European standardisation, *J. Cultural Herit.* 11 (2) (2010) 205–219.
- [18] D. Camuffo, A. della Valle, Church Heating: A Balance between Conservation and Thermal Comfort, Contribution to the Experts' Roundtable on Sustainable Climate Management Strategies, Tenerife, Spain, 2007.
- [19] H.L. Schellen, A.W.M. van Schijndel, D. Neilen, M.A.P. van Aarle, Damage to a monumental organ due to wood deformation caused by church heating, in: *Research in Building Physics: Proceedings of the 2nd International Conference on Building Physics*, Antwerpen, Belgium, 2003.
- [20] T. Broström, G. Leijonhufvud, Heat pumps for conservation heating, in: *Proceedings of the 8th Symposium on Building Physics in the Nordic Countries*, Technical University of Denmark, Lyngby, 2008, pp. 1143–1150.
- [21] L. Samek, A. De Maeyer-Worobiec, Z. Spolnik, L. Bencs, V. Kontozova, L. Bratasz, R. Kozłowski, R. Van Grieken, The impact of electric overhead radiant heating on the indoor environment of historic churches, *J. Cultural Herit.* 8 (2007) 361–369.
- [22] M.J. Varas-Muriel, M.I. Martínez-Garrido, R. Fort, Monitoring the thermal-hygrometric conditions induced by traditional heating systems in a historic Spanish church (12th–16th C), *Energy Build.* 75 (2014) 119–132.
- [23] Z. Spolnik, A. Worobiec, L. Samek, L. Bencs, K. Belikov, R. Van Grieken, Influence of different types of heating systems on particulate air pollutant deposition: the case of churches situated in a cold climate, *J. Cultural Herit.* 8 (1) (2007) 7–12.
- [24] S. Della Torre, V. Pracchi, *Le Chiese come beni culturali: Suggestimenti per la conservazione*, Mondadori Electa, Milano, 2003.
- [25] D. Camuffo (Ed.), *Church Heating and the Preservation of Cultural Heritage, Guide to the Analysis of the Pros and Cons of Various Heating Systems*, Electa, Milan, 2007.
- [26] C. Bertolin, A. Luciani, L. Valisi, D. Camuffo, A. Landi, D. Del Curto, Laboratory tests for the evaluation of the heat distribution efficiency of the Friendly-Heating heaters, *Energy Build.* 107 (2015) 319–328.
- [27] F. Redi, Santa Maria di Collemaggio. Archeologia di un monumento, in: *Celestino V e la sua Basilica*, Silvana Editoriale, Milano, 2006, pp. 71–133.
- [28] V. Gattulli, E. Antonacci, F. Vestroni, Field observations and failure analysis of the Basilica S. Maria di Collemaggio after the 2009 L'Aquila earthquake, *Engineering Failure Analysis*, vol. 34, 2013, pp. 715–734, <http://dx.doi.org/10.1016/j.engfailanal.2013.01.020>.
- [29] D. Oreni, R. Brumana, S. Della Torre, F. Banfi, L. Barazzetti, M. Previtali, Survey turned into HBIM: the restoration and the work involved concerning the Basilica di Collemaggio after the earthquake (L'Aquila), *ISPRS Annals of the Photogrammetry, Remote Sensing and Spatial Information Sciences*, vol. II-5, in: *ISPRS Technical Commission V Symposium*, 23–25 June 2014, Riva del Garda, Italy, 2014.
- [30] E. Moreci, G. Ciulla, V. Lo Brano, Annual heating energy requirements of office buildings in a European climate, *Sustainable Cities and Society* 20 (2016) 81–95.
- [31] E. Jochem, et al., Steps Towards a Sustainable Development. A White Book for R&D of Energy-Efficient Technologies, Novatlantiss, ETHZ, EPFL, Paul Scherrer Institut, EMPA, WSL, EAWAG, March 2004.
- [32] L. Lorenzo, The primary energy factors play a central role in European 2020 targets achievement, policies for Sustainable Construction, in: *Portugal SB13 – Contribution of Sustainable Building to Meet EU 20-20-20 Targets*, 2013, pp. 113–120 (Chapter 2).
- [33] UNI 10349:1994, Riscaldamento e raffrescamento degli edifici. Dati climatici, 1997.
- [34] UNI 5364 Impianti di riscaldamento ad acqua calda. Regole per la prestazione dell'offerta ed per il collaudo, 1976.
- [35] ENEA Fonti Rinnovabili, *Atlante italiano della radiazione solare*, <http://www.solaritaly.enea.it/CalcComune/Calcola.php> (last accessed 07.09.15).
- [36] N. Fumo, P. Mago, R. Luck, Methodology to estimate building energy consumption using EnergyPlus Benchmark Models, *Energy Build.* 42 (12) (2010) 2331–2337.
- [37] H.S. Rallapalli, A Comparison of EnergyPlus and eQUEST Whole Building Energy Simulation Results for a Medium Sized Office Building (M.Sc. thesis), Arizona State University, 2010.
- [38] J. Sousa, *Energy Simulation Software for Buildings: Review and Comparison*, Faculdade de Engenharia da Universidade do Porto, Porto, Portugal, 2012.
- [39] N. Aste, R.S. Adhikari, M. Buzzetti, Energy retrofit of historical buildings: an Italian case study, *J. Green Build.* 7 (2012), College Publishing.
- [40] Handbook, A. S. H. R. A. E., *Fundamentals*, 2005, American Society of Heating, Refrigerating and Air Conditioning Engineers; Atlanta. 111.
- [41] ASHRAE Handbook of Fundamental, 2005.
- [42] S. Goicoechea, P. Lopez, Modeling the air change rate in a naturally ventilated historical church. Multiple Linear Regression analysis, Faculty of Engineering and Sustainable Development, University of Gavle, 2012.
- [43] http://ac.els-cdn.com/S0360132314002376/1-s2.0-S0360132314002376-main.pdf?_tid=624f53ea-2649-11e5-8add-00000aacb362&acdnat=1436453412.883f86ea5959431390b0250ff23fe7d (last accessed 07.09.15).
- [44] UNI 10339:1995, Impianti aerulici ai fini di benessere. Generalità, classificazione e requisiti. Regole per la richiesta d'offerta, l'offerta, l'ordine e la fornitura, 1995.
- [45] H.L. Schellen, A.W.M. van Schijndel, Setpoint control for air heating in a church to minimize moisture related mechanical stress in wooden interior parts, *Build Simul.* 4 (2011) 79–86.
- [46] L. Bencs, Z. Spolnik, D. Limpens-Neilen, H.L. Schellen, B.A.H.G. Jütte, R. Van Grieken, Comparison of hot-air and low-radiant heating systems on the distribution and transport of gaseous air pollutants in the mountain church of Rocca Pietore from artwork conservation points of view, *J. Cultural Herit.* 8 (2007) 264–271.
- [47] D. Camuffo, C. Bertolin, V. Fassina, Microclimate monitoring in a Church, in: D. Camuffo, V. Fassina, J. Havermans (Eds.), *Basic Environmental Mechanisms Affecting Cultural Heritage – Understanding Deterioration Mechanisms for*

- Conservation Purposes, Quaderni Kermes, Nardini, Florence, 2010, pp. 43–47 (Chapter 3).
- [48] A.W.M. van Schijndel, *Integrated Heat Air and Moisture Modeling and Simulation*, Technische Universiteit Eindhoven, 2007.
- [49] UNI/TS 11300-2, Prestazioni energetiche degli edifici. Parte 2: Determinazione del fabbisogno di energia primaria e dei rendimenti per la climatizzazione invernale, per la produzione di acqua calda sanitaria, per la ventilazione e per l'illuminazione in edifici non residenziali – Specifica tecnica, 2014.
- [50] Technical Rules of Practice G638-1 – heating systems with radiant heaters without fans (light emitters) Planning–Installation–Operation and maintenance (Technische Regel Arbeitsblatt G 638-1 Heizungsanlagen mit Heizstrahlern ohne Gebläse (Hellstrahlern) Planung–Installation–Betrieb und Instandsetzung), 2003 (in German).
- [51] E. Dudkiewicz, J. Jezowiecki, Sensible temperature in structures heated by gas-fired direct radiant heaters (Temperatura odczuwalna w obiektach ogrzewanych promiennikami ceramicznymi), *Ciepłownictwo Ogrzewnictwo Wentylacja* 5 (39) (2008) 12–16 (in Polish).
- [52] <http://www.ceilhit.es/en/products/product-heating-film/> (last accessed 07.09.15).
- [53] <http://www.barbourproductsearch.info/Thermofoil.Data.Sheet-file044749.pdf> (last accessed 07.09.15).
- [54] D. Neilen, M.E.A. Schoffelen, H.L. Schellen, Design study of a local bench heating system for churches, performed by computer simulation, built environments and environmental buildings, in: M.H. de Wit (Ed.), 21st International Conference on Passive and Low-Energy Architecture, 19–22 September 2004, Eindhoven, The Netherlands, 2004, pp. 799–803.
- [55] R.S. Adhikari, N. Aste, M. Manfren, D. Marini, Energy savings through variable speed compressor heat pump systems, *Energy Proc.* 14 (2012) 1337–1342.
- [56] H.O. Nilsson, Comfort climate evaluation with thermal manikin methods and computer simulation models (Ph.D. thesis), Royal Institute of Technology, University of Gävle and The Swedish National Institute for Working Life, 2004.
- [57] University of Wisconsin-Madison, TRNSYS 17: A TRaNsient SYstem Simulation program – multi zone building modeling with Type 56, 2.4 Integrated Model for Thermo-Active Building Elements and 2.5 Integrated Model for Cooled Ceiling Panels Solar Energy Laboratory, University of Wisconsin-Madison, 2009.
- [58] A. Hepbasli, Thermodynamic analysis of a ground-source heat pump system for district heating, *Int. J. Energy Res.* 29 (7) (2005) 671–687.
- [59] M. Miara, D. Gunther, T. Kramer, T. Oltersdorf, J. Wapler, Heat Pump Efficiency Analysis and Evaluation of Heat Pump Efficiency in Real-life Conditions, 2011, http://wp-effizienz.ise.fraunhofer.de/download/final_report_wp_effizienz_en.pdf (last accessed 07.09.15).
- [60] B S EN 442-1:2014, Radiators and convectors. Technical specifications and requirements, 2014.
- [61] B S EN 442-2:2014, Radiators and convectors. Test methods and rating, 2014.
- [62] UNI EN 1264-3, Riscaldamento a pavimento. Impianti e component. Dimensionamento, 1999.
- [63] Regione Lombardia, Direzione Generale Ambiente, Energia e Sviluppo Sostenibile, Decreto N. 6480 del 30/07/2015.
- [64] N. Aste, C. Del Pero, Impact of domestic and tertiary buildings heating by natural gas in the Italian context, *Energy Policy* 47 (2012) 164–171.
- [65] F. Butera, Zero-energy buildings: the challenges, *Adv. Build. Energy Res.* 7 (1) (2013).